

3100

Description:

Deacon 3100 is a thermal reactive sealing compound of high temperature, pressure, and chemical tolerance that was designed to provide superior sealing performance on metal-to-metal surfaces, without chemical adhesion. This extruded putty-like material maintains characteristics of flexibility and pliability in its full range of operation so as to fill voids, cracks, and steam cuts. In the presence of heat, Deacon 3100 will form a mechanical (mechanical-type") seal. Deacon 3100 will not cement the flanges together, thus, it will not interfere with future repairs of metal-to-metal joints. Deacon 3100 is not affected by thermal cycling.

Temperature Range:

200°F to 950°F

Recommended Applications:

Deacon 3100 is ideally suited for metal-to-metal joint applications in pipeline or containment vessels that direct the flow of numerous industrial substances in gaseous, liquid, or solid form. Applications include, but aren't limited to, flange surfaces on heat exchangers, blowers, pumps, access doors, compressors, boilers, stacks, exhaust systems, turbines, and piping.

Deacon 3100 is a gasket replacement and protective barrier for metal-to-metal joints in steam or corrosive chemical environments. Deacon 3100 should be applied to the flange surface or sealing groove. When compression of the flange surfaces occurs, the material will spread to fill surface pits, warpage, and irregularities. Note: Deacon 3100 can be used with or without a fabricated gasket.

FOR INDUSTRIAL USE BY PROFESSIONALLY TRAINED PERSONNEL ONLY.

CONSULT MSDS & TECH SHEET FOR ALL SAFETY, TECHNICAL, & WARRANTY INFORMATION BEFORE USE.

NOT RECOMMENDED FOR USE ON NUCLEAR APPLICATIONS

Disclaimer: The information & recommendations of Jet-Lube LLC / Deacon concerning these products is based upon laboratory tests, customer feedback, and experience and to the best of our knowledge and belief are true and accurate. As the conditions of use are beyond the control of Jet-Lube LLC / Deacon, the company assumes no liability for damage caused by this product other than the replacement of the product or refund of the purchase price. The responsibility for determining whether or not the product is suitable for use rest solely with the purchaser. Jet-Lube LLC / Deacon recommends that the product be tested prior to use. This product is intended for a temporary repair and no agent, representative or employee of the company is authorized to alter this provision which relates to goods delivered, whether sold, delivered as samples or otherwise.

info@deaconindustries.com (800) 552-2896 or (724) 225-8008

Typical Applications:

Manufacturing (Turbine Flanges, Blowers, Pump Casings, Pumps, Threaded Fittings, Compressors, Access Doors, Boilers, Flange Surfaces, Stacks, Heat Exchangers, Piping). **Repair Applications** (Gasket Replacement, Access Doors, Steam Cut Repair, Pipeline Repair, Threaded Fittings, Cut, Warped, or Pitted Flanges).

Features:

High temperature tolerance. High chemical tolerance. High pressure tolerance. High flexibility & pliability. Creates a mechanical seal. High resistance to wear. Compatibility with thermal cycling. Fast, easy repair. Quick & simple installation. Achieves seal prior to full cure.

Packaging:

Diameter	Size	Approx. Length
1/16"	1 lb. roll	228 ft.
1/8"	1 lb. roll	124 ft.
3/16"	1 lb. roll	55 ft.
1/4"	1 lb. roll	33 ft.
3/8"	1 lb. roll	15 ft.
3/8"	5 lb. roll	88 ft.
1/2"	5 lb. roll	38 ft.
3/4"	5 lb. roll	19 ft.
Additional Sizes Available		

Directions:

An ideal situation in pressure type sealing applications is perfect flanges (lapped and polished finishes) for metal-to-metal seal with use of a joint dressing. The joint dressing acts as a lubricant to aid in flange movement during alignment and creates a gas tight seal in operation. Deacon manufactures liquid and paste sealant/gasket dressings for these applications. Since a metal-to-metal joint is not always achievable, Deacon 3100 Extruded Gasket Compound is available to create a seal where a gap is unavoidable. Deacon 3100 is compressible to within a few thousandths of an inch.

FOR INDUSTRIAL USE BY PROFESSIONALLY TRAINED PERSONNEL ONLY.

CONSULT MSDS & TECH SHEET FOR ALL SAFETY, TECHNICAL, & WARRANTY INFORMATION BEFORE USE.

NOT RECOMMENDED FOR USE ON NUCLEAR APPLICATIONS

Disclaimer: The information & recommendations of Jet-Lube LLC / Deacon concerning these products is based upon laboratory tests, customer feedback, and experience and to the best of our knowledge and belief are true and accurate. As the conditions of use are beyond the control of Jet-Lube LLC / Deacon, the company assumes no liability for damage caused by this product other than the replacement of the product or refund of the purchase price. The responsibility for determining whether or not the product is suitable for use rest solely with the purchaser. Jet-Lube LLC / Deacon recommends that the product be tested prior to use. This product is intended for a temporary repair and no agent, representative or employee of the company is authorized to alter this provision which relates to goods delivered, whether sold, delivered as samples or otherwise.

In applications of high pressure, a thick gasket creates a weak area in the joint for possible flange movement, thus creating an opportunity for the escape of gases and loss of seal. Maximum gap for high-pressure applications is .025

When trying to determine the thickness of Deacon 3100 sealant needed, a general rule for sufficient sealant compression is three times the thickness of the gap to be sealed.

EXAMPLE: 1/16" flange cut or gap = 3/16" Dia.
Sealant

Shelf Life:

Refrigeration will extend shelf life to one year in unopened containers.

Instructions:

1. Surface should be clean and dry (free from oil or foreign material to ensure proper sealing/adhesion).
2. On metal-to-metal joints, apply directly to one side of mating surface. If using a gasket, apply sealant cord to both sides of gasket or both sides of the mating surfaces.
3. To complete the seal, simply cross the two ends of the sealant cord. Sealant should be pressed firmly into place, as to resemble a tape-like seal.
4. Close and tighten joint (torqued to the equipment manufacturer's specifications if sealing a bolted flange).
5. Product will cure in service with heat.
6. Check for possible re-torque that may be required in certain situations after sealant cures to form a solid gasket.

FOR INDUSTRIAL USE BY PROFESSIONALLY TRAINED PERSONNEL ONLY.

CONSULT MSDS & TECH SHEET FOR ALL SAFETY, TECHNICAL, & WARRANTY INFORMATION BEFORE USE.

NOT RECOMMENDED FOR USE ON NUCLEAR APPLICATIONS

Disclaimer: The information & recommendations of Jet-Lube LLC / Deacon concerning these products is based upon laboratory tests, customer feedback, and experience and to the best of our knowledge and belief are true and accurate. As the conditions of use are beyond the control of Jet-Lube LLC / Deacon, the company assumes no liability for damage caused by this product other than the replacement of the product or refund of the purchase price. The responsibility for determining whether or not the product is suitable for use rest solely with the purchaser. Jet-Lube LLC / Deacon recommends that the product be tested prior to use. This product is intended for a temporary repair and no agent, representative or employee of the company is authorized to alter this provision which relates to goods delivered, whether sold, delivered as samples or otherwise.

info@deaconindustries.com (800) 552-2896 or (724) 225-8008

Note: In high pressure applications or when pressure testing at ambient, it is recommended to pre-cure with a heat gun, oven, or to dry fire / blow down at atmospheric (running heat without pressure). Unlike silicone or epoxy products, our thermosetting sealants require heat to cure.

Curing: The chart below is a general guideline for the time required for a full cure at various temperatures. A seal will be achieved before a full cure is reached.

300°F	6 hrs
400°F	4 hrs
500°F	3 hrs
600°F	1 hr
700°F +	<1 hr

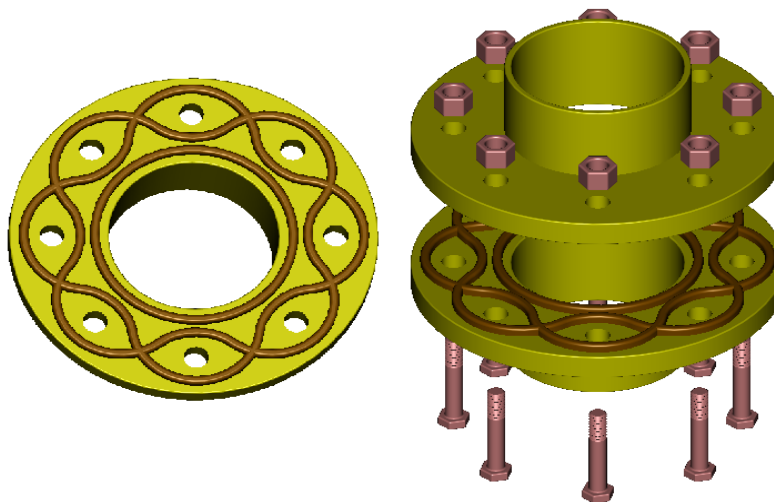

FOR INDUSTRIAL USE BY PROFESSIONALLY TRAINED PERSONNEL ONLY.

CONSULT MSDS & TECH SHEET FOR ALL SAFETY, TECHNICAL, & WARRANTY INFORMATION BEFORE USE.

NOT RECOMMENDED FOR USE ON NUCLEAR APPLICATIONS

Disclaimer: The information & recommendations of Jet-Lube LLC / Deacon concerning these products is based upon laboratory tests, customer feedback, and experience and to the best of our knowledge and belief are true and accurate. As the conditions of use are beyond the control of Jet-Lube LLC / Deacon, the company assumes no liability for damage caused by this product other than the replacement of the product or refund of the purchase price. The responsibility for determining whether or not the product is suitable for use rest solely with the purchaser. Jet-Lube LLC / Deacon recommends that the product be tested prior to use. This product is intended for a temporary repair and no agent, representative or employee of the company is authorized to alter this provision which relates to goods delivered, whether sold, delivered as samples or otherwise.